

# Limiting factors for carbon-based chemical double-layer capacitors

M. Frank Rose\*, C. Johnson, T. Owens and B. Stephens

*Space Power Institute, 231 Leach Center, Auburn University, Auburn, AL 36849 (USA)*

## Abstract

The chemical double-layer (CDL) capacitor improves the energy storage density dramatically when compared with conventional electrolytic capacitors. When compared to batteries, the CDL capacitor is much less energy dense, however the power density is orders of magnitude better. As a result, CDL-battery combinations present an interesting pulse power system with many potential applications. Due to the nature of the CDL, it is inherently a low voltage device. The applications of the CDL can be tailored to auxiliary energy and burst mode storages which require fast charge/discharge cycles. Typical of the applications envisioned are power system backup, directed energy weapons concepts, electric automobiles, and electric actuators. In this paper, we will discuss some of the general characteristics of carbon-based CDL technology, describing the structure, performance parameters, and methods of construction. Further, analytical and experimental results which define the state-of-the-art are presented and described in terms of impact on applications.

## Introduction

The major electrical energy storage systems of use in pulsed applications are capacitors, batteries and inductors. The application of inductive storage, except for short storage times, is dominated by the need for cryogenics and superconducting material. Consequently, the intermediate storage needs have been almost totally dominated by batteries and capacitors or some combination of the two. Although the battery has high energy density, it suffers from low power density and a limited number of charge/discharge cycles. The highest energy density, low voltage capacitors to date have been the electrolytic capacitors. While high power density is possible, the units are polarity sensitive and in the high power versions, must be conditioned to maintain a fully functioning unit. It is used extensively for voltage smoothing in power systems. The chemical double-layer (CDL) capacitors, using aqueous electrolytes, have power densities much better than electrolytics and at least an order of magnitude better than the best conventional batteries.

In 1887, Helmholtz discovered that the interface between a conductor and a liquid electrolyte formed a layer capable of storing charge. For strong electrolytes, this layer [1] is estimated to be only a few angstroms thick. Due to the fact that there are materials with surface areas of a thousand square meters per gram, it is possible to engineer practical capacitors with the surface area, interface thickness ratio on the order of the inverse of the permittivity of free space. This results in capacitors with

---

\*Author to whom correspondence should be addressed.

a capacitance greater than 1 F in a volume on the order of a 'dime'. This technology was first pursued to practice by SOHIO [2] and NEC [3], and there are a considerable number of units commercially available for low voltage, high impedance applications. These units usually employ a rare earth oxide or some form of carbon as the large surface area materials. There are a number of electrolytes, both aqueous and organic, available for use in these capacitors. The ultimate choice is governed by the application. In general, use of the organic electrolytes increases energy storage density at the expense of internal resistance.

There are numerous potential applications for the CDL technology. To date, they are used for memory backup, and as short-term backup power supplies. They are currently being investigated for such applications as electric vehicle acceleration and electromagnetic actuation. The restrictive number of applications is due in part to the need for pressure to reduce the equivalent series resistance to low values. While easy to achieve in a laboratory prototype, it is difficult to produce a commercial product with a pressurizing system. Further, due to the differences in pore geometry, the capacitance is very much a function of frequency which tends to make application at d.c. or less than 60 Hz the primary region of operation. For high energy/power density applications, the ultimate device would possess the energy storage characteristics of a battery and the power characteristics of a capacitor. The CDL technology is a step in the right direction. During the past five years, there have been significant technological advances which tend to extend the range of applications by engineering out the need for pressure to obtain low internal resistance and by optimizing the pore geometry for a particular application. In that sense, they are 'designer' devices which can be custom tailored to a particular task. The limits of CDL technology using carbon as the large surface area material have been explored extensively at the Space Power Institute. The remainder of this paper will present some of our results.

## Capacitor structure

### *Double-layer capacitor geometry*

Figure 1(a) is a schematic drawing of a practical embodiment of the CDL technology utilizing carbon as the large surface area material. The carbon beds and membrane are soaked in a suitable electrolyte such as dilute solutions of sulfuric acid or potassium hydroxide. For powder beds, a seal is necessary to hold the powder in place, confine the electrolyte and serve as a confining medium when the finished product is placed under pressure to increase the contact area between individual particles in the compact. The end plates are chosen for compatibility with the electrolyte and are as thin as possible. The porous membranes are suitable plastics which can be obtained in a variety of thicknesses and porosities. The rough equivalent electrically is that of two capacitors connected in series with the interconnect being the distributed electrolyte which ensures contact with the double layer. On the 'other side of the capacitor', electrical contact is made through the individual carbon grains to the metallic end plates. It is obvious that the resistance of this path is greatly determined by the surface contact area between the individual grains and the position of any given grain within the bed. As a result, it is necessary to add considerable pressure to this geometry to reduce the internal resistance to a value which is acceptable. For potassium hydroxide electrolyte, 0.0025 cm nickel is chosen for the end plates and 0.0025 cm Nafion separators are used in laboratory cells. The thickness of the carbon bed is varied up to several millimeters as needed.

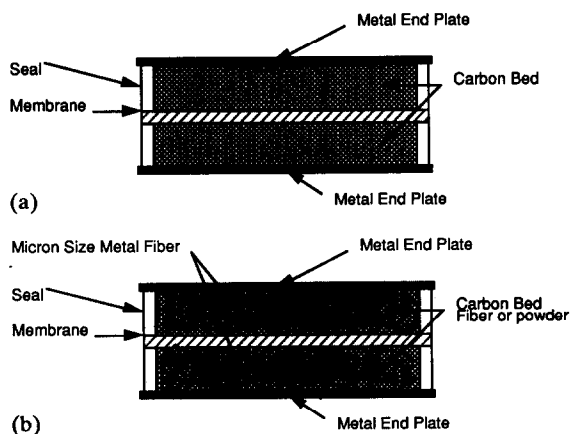

Fig. 1. (a) Schematic drawing of a packed carbon powder bed chemical double-layer (CDL) capacitor. (b) Schematic drawing of a chemical double-layer (CDL) capacitor using a composite electrode structure.

Figure 1(b) illustrates a capacitor structure which greatly reduces the need for pressure to produce a low equivalent series resistance. The active area in the capacitor is now made up of sinter-locked fine metal fibers with diameters of a few microns interspersed throughout the bed of large surface area material. This unique composite can be made with high uniformity using standard paper making technology and has been described in detail elsewhere [4]. To further enhance conductivity, the metal fibers are also sinter-locked to the metallic end plate which is of the same material as the fibers. The metal fibers drastically reduce the resistance associated with the carbon bed by providing larger metallic surface area for the individual grains or fibers of carbon to contact electrically. Capacitors made in this fashion show little or no pressure dependence of the equivalent series resistance.

## Double layer

It is very difficult to directly probe the interface between the metallic conductor and an electrolyte interface. There are a number of theoretical models [5, 6] whose only means of verification is the ability to predict macroscopic measurements such as capacitance and the charge storage associated with the double layer. The key parameters of interest for the double layer as an energy storage media are the value of the relative dielectric constant associated with the region in which the charge is stored, the thickness of the layer and the voltage at which the layer fails. These parameters are functions of the electrolyte species, and its concentration. Rose [1] has used a modified version of the Guoy-Chapman theory to calculate the thickness of the double layer as a function of concentration for strong aqueous electrolytes such as sulfuric acid and potassium hydroxide. This model shows that the storage layer decreases with electrolyte concentration to molecular dimensions which is consistent with the assumption that the energy storage media is essentially a single layer of molecules of the solvent. For aqueous electrolytes, this dimension is that of the water molecule and is on the order of angstroms. Fundamental studies by Bockris [6] indicate that the relative dielectric constant of this layer is on the order of 10. From an engineering perspective, the

practical limit to voltage standoff occurs when the potential needed to dissociate the water is exceeded. That value is about 1.2 V per cell. Substitution of these estimates of the critical parameters into the expression for capacitance indicates that it should be possible to build capacitors with capacitance on the order of 20–50  $\mu\text{F}$  per real square centimeter of surface area. This is in general consistent with experimental results.

### Large surface area materials

Materials such as the activated carbons are highly fractionated with enormous surface area as a result of the structure pores. The large surface area materials most often used in the double-layer capacitor technologies are the rare earth oxides and carbons such as 'carbon black'. In general, the carbons have the highest surface areas. It is possible to purchase commercially available materials which have surface areas greater than 2000  $\text{m}^2/\text{g}$ . Surface area of this magnitude is only achievable with a highly porous structure with average pore dimensions of a few angstroms in diameter. Activated carbon purchased from the American Norit Company, Inc., specifies that the surface area is about 1500  $\text{m}^2/\text{g}$  with a mean pore dimension of 22 Å. Clearly, pores with dimensions on the order of twice the double-layer thickness or less cannot be used to store charge. As a result, much of the surface area is not accessible in any finished device. Further, it is necessary for the electrolyte to penetrate the pore in order that a conducting path be available to the external circuit. Consequently, the resistance from each micropore to the external circuit is dependent upon its size and position within the carbon bed. Clearly a trade-off exists between the surface area and the pore dimensions for a particular application. Figure 2 is an approximate circuit diagram for a CDL. Starting at the top of the Fig., the external resistance  $R_{\text{ext}}$  is associated with the external circuit, load, diagnostics, etc., and is under the control of the experimenter. Since the total capacitance of the array is the sum of the capacitance of billions of tiny pores, of differing values, in parallel, it is instructive to examine how the array is structured at least qualitatively. Since there is mirror symmetry in the unit, it is sufficient to examine the electrical pathways only to the membrane. For a given pore, there is the resistance associated with the current carrying path through the metallic end plate/metallic fibers and through the fiber/grains of carbon. In a porous bed with many fibers/grains tightly packed, there are a number of current-carrying paths of various resistances possible from any given pore. The value of the resistance associated with that path is a function of the packing parameters, pressure,

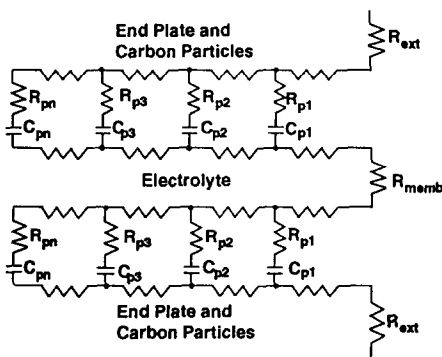

Fig. 2. Approximate schematic for a chemical double-layer (CDL) capacitor.

resistivity of the bed material, resistivity of the metallic end plates, and position within the bed. The Helmholtz double layer discussed above represents the 'dielectric' or energy storage media in the usual sense. Passing through the double layer, the conducting electrolyte in the pore constitutes the other conducting electrode. The specific resistance of a pore will be a function of the diameter and length of the pore and has been designated as  $R_p$ . In similar fashion, the electrolyte is distributed throughout the interstices of the bed-forming multiple pathways to the porous membrane. The resistance  $R_{\text{memb}}$  is a function of the porosity of the membrane and is readily determined by experiment to be essentially the percent porosity times the resistivity of the electrolyte. Note that each pore is connected to its neighbor by shunt resistances which are functions of the resistivities of the constituents. The net result is that charge can be redistributed during and after a discharge event which has not totally depleted the stored energy. While a nuisance, this is not particularly of concern for most of the applications being considered today.

### *Electrolytes*

Numerous electrolytes have been used for chemical double-layer capacitor construction. The most common of the aqueous electrolytes are sulfuric acid and potassium hydroxide. The most desirable characteristic of these electrolytes are their low resistivity. Since they are aqueous based, it is necessary to operate each cell of the capacitor at a voltage less than 1.2 V. Further, these electrolytes are corrosive, which places restrictions on the use of materials for long-life devices. By contrast, organic electrolytes such as propylene carbonate with lithium and ammonium salts have electrical resistivities at least an order of magnitude greater than that of aqueous electrolytes. Organic electrolytes have been operated at voltages as high as 3.5 V in practical devices. Since the energy storage density is proportional to the square of the charge voltage, it would appear that organic electrolytes would be desirable. Many commercial devices now employ organic electrolytes. However, the internal resistance of the finished capacitor is usually 10's of ohms. This high value of internal resistance limits application.

### *Operating cell characteristics*

In our laboratory, we have concentrated exclusively on the use of aqueous electrolytes and carbon materials for the large surface area. Our reasoning for these choices are the ready availability of cheap, well-characterized materials which need no exotic processing to manufacture. The general model for a capacitor is that of a pure capacitance shunted by the equivalent parallel resistance (EPR) and in series with the equivalent series resistance (ESR). Figure 3 shows the pressure dependence of the ESR for a series of cells areas from 2 to 5 cm<sup>2</sup> and with various thicknesses. In general, the ESR decreases rapidly with pressure for all thicknesses investigated. There is almost an order of magnitude variation of the ESR for the capacitors made from packed powder beds. For many applications, it is desirable to reduce the ESR to an absolute minimum. While it is easy to apply pressure to small devices, it is far more difficult when large storage capacitors are desired. As was discussed earlier, the physical mechanism responsible for the decrease in ESR with pressure is the increase in contact area between individual grains in the bed and a reduction of the path through the electrolyte as the bed is compacted. To first order, the effect is independent of powder bed thickness and shows the same relative decrease with pressure. The horizontal line in Fig. 3 is the data taken for a composite electrode made from 2 mm large surface area carbon fibers roughly 10  $\mu\text{m}$  in diameter mixed with 2 mm nickel fibers with a diameter of 2  $\mu\text{m}$ . The mix ratio was 2:1 by mass. Cellulose was added and the mix

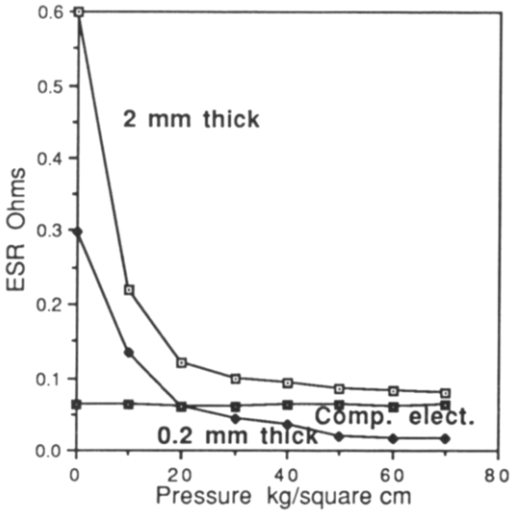

Fig. 3. Pressure dependence of the equivalent series resistance (ESR) for powder and composite electrode structures.

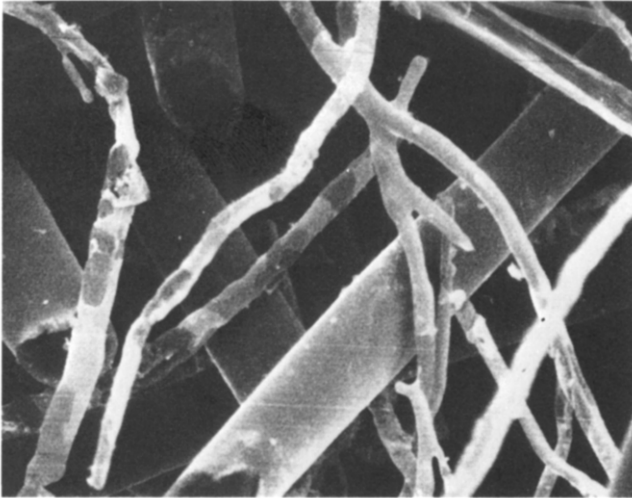

Fig. 4. Electron micrograph of composite electrode structure showing large carbon fibers and smaller sinter-locked metal fibers.

converted to a paper sheet using standard paper making equipment. Selective annealing in a hydrogen atmosphere reduced the cellulose and produced a sinter bond to the nickel backing plate and between fibers. Figure 4 is an electron micrograph of a typical sintered structure. The larger fibers in the picture are the carbon fibers. Note that the smaller metallic fibers are effectively bonded and contact the large fibers at many points along their length. In this way, extremely good contact between the metal end plates, the carbon fibers and the metal fibers are maintained with little or no pressure dependence of the ESR.

Since all of the elements of the CDL have resistivities which are functions of temperature, packed powder bed capacitors were made and operated from about 6 to 24 °C. The results are shown in Fig. 5. The ESR, over the range measured, changed by about 30% and is almost totally due to the change in resistivity of the electrolyte and the thermal contraction of the grains which reduces the contact area. The change in the electrolyte is the dominant term and accounts for roughly 80% of the observed changes. Higher temperature behavior has not been investigated within the program. These data do point clearly to the fact that application of these devices in a situation with large temperature extremes will require environmental control. It is obvious that the lower limit to operating temperature is the point at which the electrolyte freezes. Practical consideration of the ESR requirements will certainly limit the temperature variation for the electrolyte to a few degrees about some design point. Since the ratio of the load impedance to the ESR determines the available usable energy, it would appear advantageous to operate the CDL at higher temperature for low impedance loads. Chemical double-layer capacitors are 'designer devices' which can be custom tailored to a particular application and temperature of operation is a variable which can be exploited.

Of equal interest is the equivalent parallel resistance (EPR). In general, single-cell capacitances of farads are readily attainable. An EPR of a kilohm allows storage time constants on the order of thousands of seconds. In general that is sufficient for many applications. However, applications demanding long-term storage may require trickle charging to maintain the requisite energy. Clever design of a device might result in the losses through internal currents sufficient to maintain the temperature at the most desirable operating point if operating in a cold environment. The nature of the EPR is not clearly understood. It appears to be influenced by the 'purity' of the material in so far as that dependence might be mirrored by manufacturing processes. Adsorbed material on the surface of the carbon and impurities in the electrolyte could provide sufficient conduction through the double layer to account for the experimental observations. Figure 6 is a bar chart which shows the EPR for devices made from several carbon powders. All units were comparable in size and operated at room

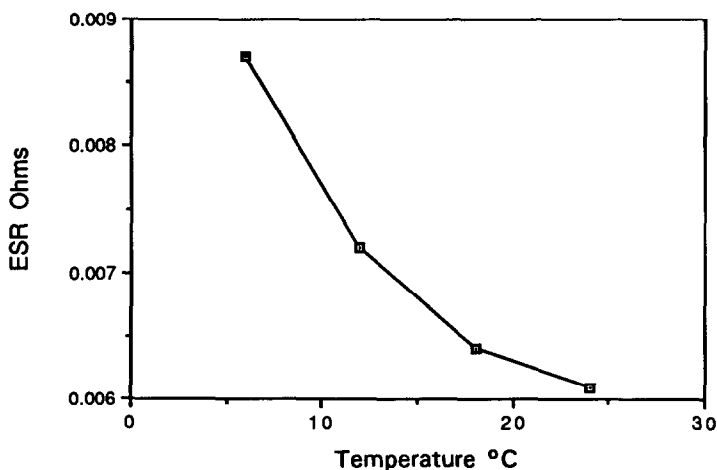

Fig. 5. Temperature dependence for the equivalent series resistance (ESR) for a packed carbon bed capacitor using  $\text{H}_2\text{SO}_4$  electrolyte.

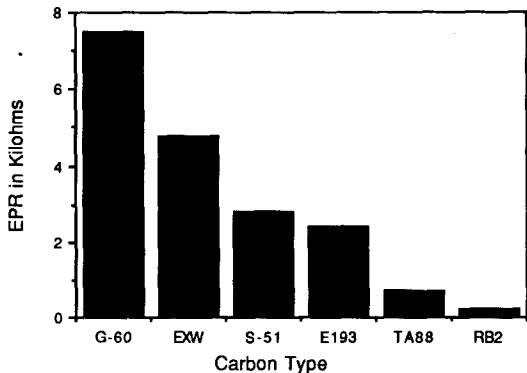

Fig. 6. Equivalent parallel resistance (EPR) for cells made with packed carbon beds using carbon powder from several commercial sources.

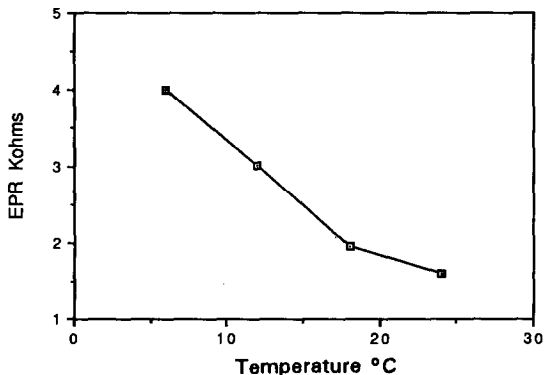

Fig. 7. Equivalent parallel resistance (EPR) as a function of temperature for a packed carbon bed device.

temperature. While the carbons had differing surface areas and pore size distributions, they were made by differing processes. While indicative of residual from processing, we were not able to verify that conclusion. If the EPR were a conduction process as described above, there should also be a strong correlation with temperature. Figure 7 illustrates the same temperature dependence as was observed in the EPR, clearly pointing to conduction through the electrolyte as the mechanism determining the EPR.

Over the range of temperatures investigated and for a constant pressure of 20 kg/cm<sup>2</sup>, there was no temperature dependence of the capacitance. Since the beds investigated were tightly packed powder, after a minimum pressure, there was sufficient contact that almost all of the material was accessed for capacitance. Figure 8 illustrates the pressure dependence of the capacitance for two cells of the same area but of differing thicknesses. These cells were not made from the same carbon and the beds may not have been packed to the same density. Therefore, the capacitance does not appear to scale linearly with thickness as would be expected. The purpose of this graph is to show that the pressure dependence of the capacitance is weak and not a factor in the design of powder bed CDL capacitors. Similar results are observed



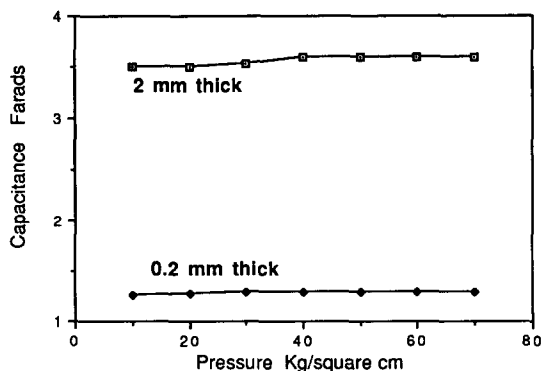

Fig. 8. Pressure dependence of the capacitance of a packed carbon bed CDL for two bed thicknesses.

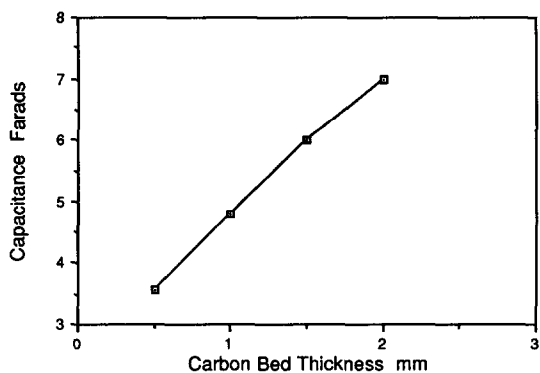

Fig. 9. Unit cell capacitance as a function of the thickness of the packed powder bed.

for the composite electrodes. Figure 9 is a plot of the capacitance for a number of cells of differing thickness, made from the same material, while trying to maintain the construction parameters identical. Packed powder beds are difficult to make uniformly. Intuitively, the capacitance should scale linearly with thickness. To within the accuracy of our measurements, linear scaling is observed but the slope is less than expected. The difficulty may be in the ability to accurately produce thick beds with equivalent packing density.

## Discussion

There are two options for practical application. A single device can be constructed uniquely in one unit for a particular application. In that case, the desired voltage can be met by a bipolar stack of the requisite number of unit cells  $C_u$ . In order to achieve the desired value of the internal resistance, ESR and EPR, and total capacitance, the area and thickness of the cell can be adjusted to arrive at suitable parameters. Depending upon the application, design by this procedure may result in more energy than is optimum for the load. Referring to Fig. 3, it is possible to construct single cells which allow 'short circuit' currents as high as 5–10 A/cm<sup>2</sup>. For a given area, the

ESR and the  $C_u$  scale linearly with thickness of the active bed. This procedure results in the highest energy/power density by optimizing the packaging. More generally, a 'standard' module made up of a number of unit cells can be built and any energy storage unit made up of the requisite number of standard modules in series/parallel arrays. Again, depending upon the load, it may not be possible to optimize all parameters of the storage unit simultaneously.

There is a wide variety of materials and techniques available for utilization in CDL technology. The current laboratory state-of-the-art is about 6 J/g for aqueous electrolytes with the capacitive elements made from composite electrodes. For non-aqueous electrolytes, the energy density is at least double that amount. For internal resistance, the best ESR values for aqueous electrolytes is on the order of  $0.1 \Omega/\text{cm}^2$  of active cell. The thickness of the cell for these values is 0.002–0.003 cm. Simple bipolar stacks from the carbon powder bed technology have been constructed to evaluate sealing and any engineering problems which might occur as large numbers are stacked for higher voltage operation. Up to 50 cells have been made, and little or no problems have been encountered. The largest of these experimental units operated at 50 V and stored 1200 J. The energy density was greater than 3 J/g even though no care was taken to minimize the materials used in the construction. The unit was tested periodically for several months with little or no degradation.

Further advancements in this technology must rely on engineering of the pore structure to maximize the surface area available while simultaneously maximizing the pore diameter. It is probable that factors of 2 or more improvement can be realized by a concerted effort.

### Acknowledgement

This work was supported by the Strategic Defense Initiative Organization's Office of Innovative Science and Technology (SDIO/TN) through contract number DNA001-91-C-0127 with the Defense Nuclear Agency.

### References

- 1 M.F. Rose, *Proc. 33rd Int. Power Sources Symp., Cherry Hill, NJ, USA, June 13–16, 1988*, The Electrochemical Society, Pennington, NJ, USA, pp. 572–592.
- 2 D.L. Boos, H.A. Adams, T.H. Hacha and J.E. Metcalfe, *Proc. 21st Electronics Components Conf., 1971*, pp. 336–342.
- 3 K. Sanada and M. Hosokawa, *NEC Res. Dev.*, 55 (1979) 21–28.
- 4 D. Kohler, J. Zabasajja, A. Krishnagopalan and B. Tatarchuk, *J. Electrochem. Soc.*, 137 (1990) 136–141.
- 5 I.L. Cooper and J.A. Harrison, *Electrochim. Acta*, 29 (1984) 1147–1159.
- 6 J.O'M. Bockris, *Mater. Sci. Eng.*, 53 (1982) 47–64.